

Chlorine dioxide preparation- and dosing units

CDG



sera
Seybert & Rahier

sera - Chlorine dioxide production- and dosing units

of series CDG are dosing units for an efficient preparation and exact dosing of 2% chlorine dioxide solutions. Performance range up to 1.000 g ClO₂/h, at pressures up to max. 10 bar.

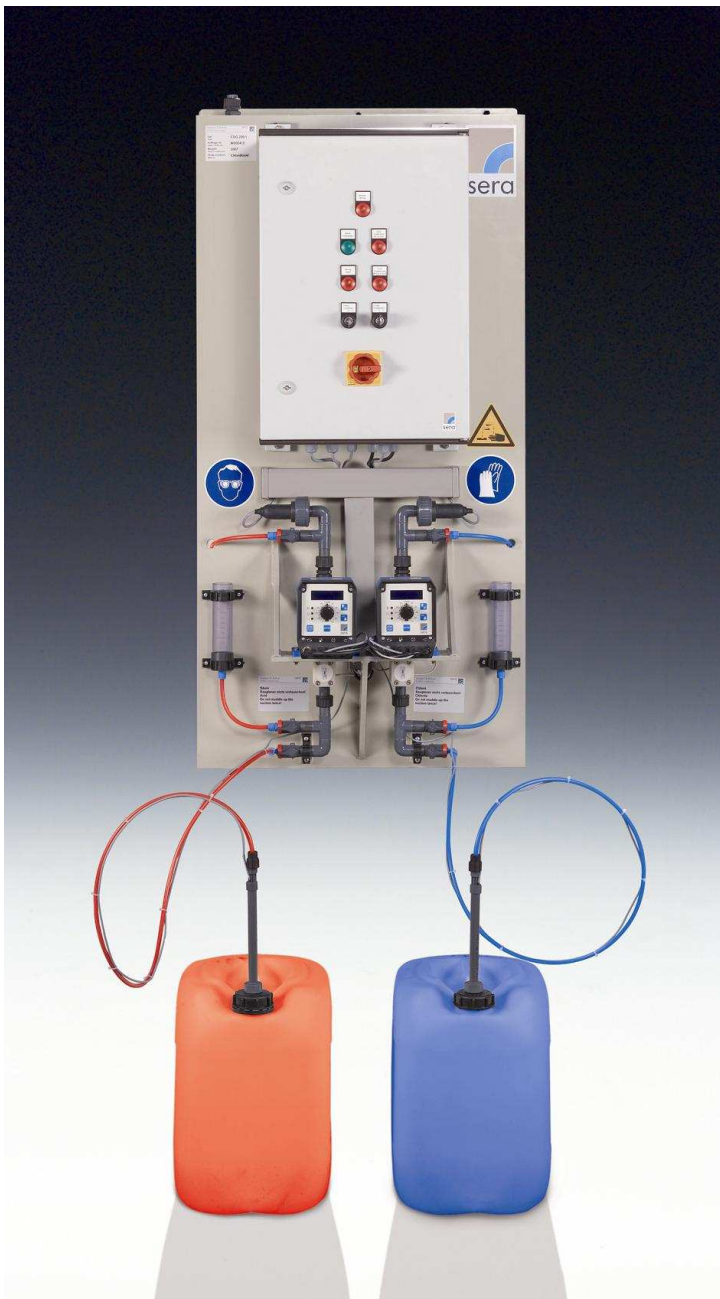

Operative range

Desinfection of drinking, industrial and cooling water, removal of biofilms in pipe systems, pH-value-independent disinfection etc.

Performance features

- Highest accuracy
- Excellent efficiency factor
- High operational safety
- High quality materials
- Easy to operate
- Flexible controlling
- Low operational costs
- Compact design
- Continuous operation

Chlorine dioxide preparation- and dosing units



sera

Seybert & Rahier

CDG

Function

By means of the sera – CDG – unit series 2% chlorine dioxide solutions are produced from 9% hydrochloric acid and 7.5% sodium chlorite according to the acid/chlorite process.

The units primarily consist of two controllable dosing units, two flow meters, the reactor as well as the control.

The capacities of the pumps are permanently measured and are coordinated so that both chemicals are fed into the reactor in a ratio of 1:1.

Here both reagents are transformed into ClO_2 .

Chlorine dioxide is produced for example, proportional to a main stream or in dependence on a chlorine dioxide measurement.

Advantages of chlorine dioxide

- Excellent bactericidal properties
- Consistent effect over a wide pH-range
- Better effect than chlorine at the same concentration
- No formation of chlorophenol (formation of odour and taste)
- No formation of THM (Trihalogenmethan)
- Long-lasting bactericidal and bacteriostatic protection
- No reaction with ammonium and amino-compounds, therefore no formation of nitrosamines (cancer-causing)
- Good sporicidal, viricidal and algicide properties
- Removal of odour, taste and colouring
- Decomposition of biofilms in the pipe at permanent action of small quantities.

Design

Pos.	Designation
1	HCl - tank
2	NaClO_2 - tank
3	Suction lances
4	Flow meter
5	Calibration pots
6	Dosing pumps
7	Overpressure safeguards
8	Reactor
9	Shut-off valve
10	Control

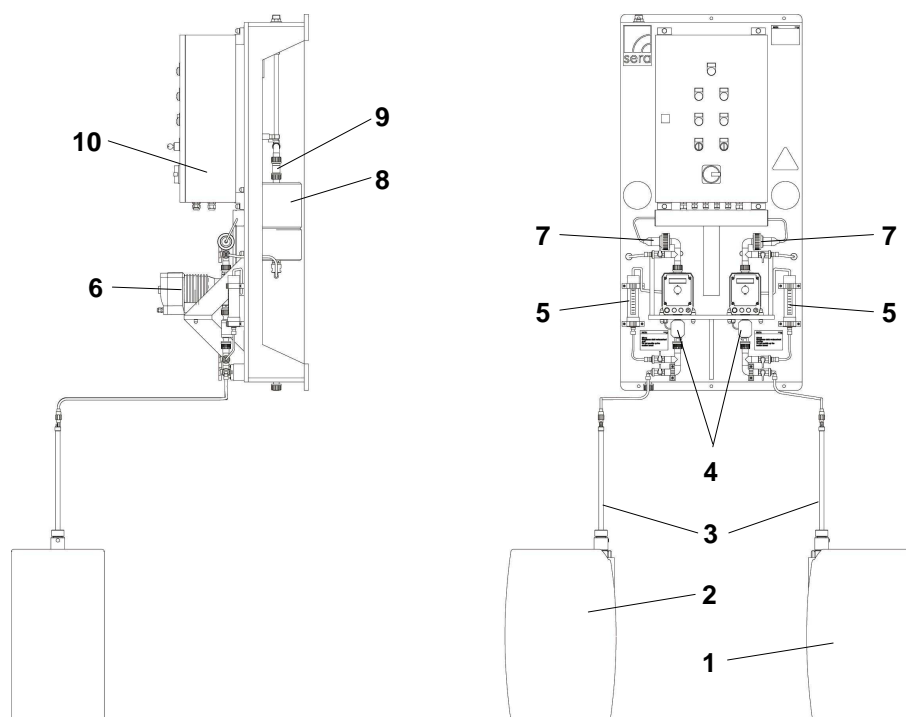

Chlorine dioxide preparation- and dosing units



sera

Seybert & Rahier

CDG

Technical data

Type	Capacity *	Chemical consumption [litre / hour]		max. permissible counter pressure [bar]	Weight (empty) [approx. kg]
	ClO ₂ [g/h]	HCl (9%)	NaClO ₂ (7,5 %)		
CDG - 125.1	125	3,2	3,2	10	64
CDG - 220.1	220	5,5	5,5	10	64
CDG - 500.1	500	12,6	12,6	10	70
CDG - 1000.1	1000	25,2	25,2	10	75

* other capacities on request

Electrical Data / Control technology

Input (The control must be potential-free)	4 digital inputs	Impulse input (optionally change-over to analog), Automatic external ON, Fault external controller, External flow bypass
	1 analog input	4...20 mA
Output	3 potential free outputs	Pre-alarm tank, release external controller, collective fault
	1 outgoing voltage	230V / 50/60 Hz / 2A (e.g. for external controller)
Enclosure	Control cabinet	IP65
Supply voltage	230V / N / PE / 50/60Hz	
Power consumption CDG-125.1 / CDG-220.1 CDG-500.1 / CDG-1000.1	approx. 1,0 kW approx. 1,5 kW	

Chlorine dioxide preparation- and dosing units



sera

Seybert & Rahier

CDG

Standard - scope of delivery

- 2 controllable diaphragm dosing pumps (C-serie)
- 1 reactor
- 2 pressure switches
- 2 flow meters
- 2 gas tight suction lances with pre-alarm + run dry protection
- 2 adapters for suction lances for drum
- Control (impulse / analog input)
- Fittings, hoses, piping
- Frame for wall-mounting

Accessories (optionally)

- Thinning water unit
- Chemical gas absorber (HCl)
- Chemical gas absorber (NaClO₂)
- Contact water meter (main line)
- ClO₂ – measuring and control unit
- ClO₂ - photometer for fast determination of ClO₂ - concentration
- Drum for HCl (without filling)
- Drum for NaClO₂ (without filling)
- Drum for HCl (incl. filling)
9 - percent solution (30 or 60 litre)
- Drum for NaClO₂ (incl. filling)
7,5 - percent solution (30 or 60 litre)
- Collecting basin (for drum)
- BUS - connection



sera

Dosieren

Fördern

Verdichten

Seybert & Rahier
GmbH + Co. Betriebs - KG

sera-Straße 1 · D-34376 Immenhausen
Tel. + 49 56 73 99 90
Fax. + 49 56 73 99 91 55
e-mail: info@sera-web.de
Internet: www.sera-web.de

sera – Representative:

